

Implement of Medical Application Over High Speed Wireless Broadband Network System in Thailand

S. Noimanee¹, W. Senavongse¹, S. Tantisatirpong¹, and K. Noimanee²,

ABSTRACT

This paper present the functional parts of a wireless broadband network system (WBBNS), its basic operation and medical application in Thailand. Our research explain how it can use base stations to provide wireless high speed data connections that can be used for voice, medical data and medical consult video services (MCVS) to distances of over 20 km. Anywhere, the project aimed to research develop of high speed wireless broadband network for medical applications of Medical Center, Prince Maha Chakri Sirindhorns, HRH Princess Siridhorn (MSMC), Amphor Ongklaruck, Nakhon Nayok Province, Thailand. This project is integrating other sciences, biomedical engineering, telecommunications engineering, electronic engineering and computing technology. Includes both direct medical and other. We have focus on medical care, community living around the area radius of the radio wave propagation in the district that spreads to the 2.500-2.520 GHz standard of wireless broadband technology of Thailand. This project involved 2 Subprojects, namely: Firstly, is development of multi patient monitoring on wireless broadband technology around MSMC. And finally subproject is primary health care mobile doctor around MSMC

Keywords: WBBNS, Medical applications, Prince Maha Chakri Sirindhorns (MSMC), MCVS, HRH Princess Siridhorn, High-speed wireless broadband network, 2.500-2.520GHz frequency range, Multi patient monitoring, MSMC.

1. INTRODUCTION

Thailand is today considered to be the top Medical services with a very successful hospital center best service more than 80% of world services share. In the quest to identify the next generation medical service, the hospital center in Nakorn Nayok province chose WBBNS-Thai Biomedical Engineering

Manuscript received on June 9, 2015 ; revised on December 12, 2015.

¹ Department of Biomedical Engineering, Faculty of Engineering, Srinakharinwirot University, 63 Moo 7, Ongkharak, Nakhon Nayok 26120, THAILAND.

² Department of Computer Engineering, Faculty of Engineering, Rajamangala University of Technology Lanna Chiang Mai, 123 Haay Keaw Rd., Chiang Mai 50200, THAILAND. E-mail: dr.suranan@gmail.com, beau.suchada@yahoo.com, wongwit@g.swu.ac.th and all_of.none@hotmail.com,

Research Association (ThaiBME) forum-defined implementation of medical services through a WBBNS technology-to open up another frontier in the medical services. In 2012, the committee ThaiBME group of Executive ThaiBMEs staff developed a WBBNS system with National Telecommunication Commission, which states WBBNS technology will be a focus for the future of Thailand Medical Center Services (MSMC), and will be the preferred technology to deliver e-Health, medical consult in the Mobile WBBNS program. The Mobile-WBBNS program and medical application acceleration projects, which aim to develop medical services and base stations, were initiated under this system. Towards this end, medical center (Prince Maha Chakri Sirindhorns) offers only world class services capability, and also an entire service, medical consult trough an WBBNS television, by forming its own system. Forming a complete WBBNS system structure, including 2.5GHz base station, CPE, network elements, physician teams, system integration, medical application, ICT operation and services, is part of the overall strategy adopted by MSMC for development of technology. Cooperating with MSMCs physicians, and leveraging the strengths of its medical services group, Thailand is able to speed up system development, medical services and technology of WBBNS system. WBBNS spectrum with good physical characteristics, which is crucial to network deployment, has been planned and will be released by September 2012 to facilitate the MSMC program and subsequent medical work of WBBNS systems. To promote global interoperability MSMC actively participates in international standards of medical services and promotes international collaborations. Thailand has been working closely with the NTC forum in promoting and sharing physician-Thailand experiences. Section 2 of this case study describes structure of WBBNS system, Section 3 discusses WBBNS testing on site, Section 4 describes vital-sign measurement through WBBNS network, Section 5 describes antenna design for WBBNS system, Section 6 describes the design of experiment, Section 7 describes WBBNS equipments and software configuration and Section 8 provides conclusions. The material for this paper was provided by Assoc.Prof.Dr. Suranan Noimanee of computer engineering; who is the liaison for NTC of Thailand forum. We coordinated contributions from other members of ThaiBME and Srinakarinwirot University, was prepared by Plannet Commu-

nications company Ltd. on behalf of the liaison for WBBNS of NTC forum. Contributors were: Professor Prasit Prapinmongkolkarn Chairman of the National Telecommunication (NTC) of Thailand and Mr. Prapat Ratleardkarn. Anyway, HRH Princess Maha Chakri Sirindhorn Medical Center has revised its plan to proceed. Because of the need to strengthen information systems and basic medical services are available within the Medical Center. Before you take a high-speed wireless broadband is set to be released to the medical center's medical services. They tried working on the biomedical engineering researchers project's to bring their medical application. Such as in medical applications, the vital-signs measurement from faculty of engineering, Chiang Mai University, faculty of engineering KMUTL and faculty of Science, KMUTL etc.,. The medical center has received donation from the National Telecommunications Commission in amount of 1,000,000 USD. Its original purpose was:- Firstly, to give a royal charity dedicated to occasion age of a King Bhumibol Adulyade 80th birthday. Secondly, to provide a center for developing and linking information of the patients data. And services both inside and outside the medical center for development of public health data system. Thirdly, to develop information technology computer network in order to manage the data and knowledge of public health center, clinical network, hospital around the province and other servers. Next, to create a network of research and knowledge management, medical and public health. Finally, to develop information systems in facilitating services for patients at the referral center at the medical center and returned to community raised area. Therefore, to test the feasibility of adopting WBBNS technology to try to establish a new communication channel called telemedicine application for medical research talk face to face method. Called long-distance consultation with in various medical information. Such as vital-signed and medical images in digital format is the central of the medical center to the health substation, include mobile client unit. And to study their effects such as interference of high speed broadband spectrum with the old system in medical center located. By studying the possibility of bringing the WBBNS technology. Used to medical services. The medical center as a lead agency in managing the project and is the medical network hub. There was conducted in the following area is completed. They connected via radio frequency to client 2 health substations in Nakorn Nayok province. In this paper, we proposed medical application by WBBNS technology used to create new communication channels to the National Telecommunications Commission. At the end of the period of project. Substance of the report covers issues such as requirements and technical feasibility. Telecommunication network features and components that contain the details of the spectrum, the routes to and use of network calls. Transportation costs in serving as a model to develop in the fu-

ture. For monitoring and evaluation centers. Physician or medical doctors had been monitoring and evaluation of every project and report results to the Office of National Telecommunications Broadcasting and Telecommunication Commission (NBTC) to, as mentioned above. Detailed results of the project are as follows:- Activities planed: Education and development of medical applications, including vital signs monitoring of patients on the ambulance station. Health Center houses the public that medical doctors are required to determine the radius of the house is surrounded by high-speed wireless broadband of the hospital information system development the medical information system of a medical imaging center. The Medical/analysis under the three sub-projects including. Firstly, Sub-project 1st: Development of Multi Patient Monitoring on WBBNS Technology Around MSMC and secondary is Sub-project 2nd: Primary Health Care Mobile Doctor Around MSMC.

2. SYSTEM IMPLEMENTATION

2.1 Structure of system profile.

A WBBNS technology as certification follow the IEEE 802.16 space interface specifications from IEEE organization. The network specifications of WBBNS hardware product. However, they are being developed internally by the WBBNS of NTC Thailand forum, which include the end-to-end networking specifications and network interoperability specifications. The Network Working Group within the WBBNS forum is responsible for these network specifications, some of which involve Access Service Network (ASN) control and data plane protocols, ASN profiles, Connectivity Services Network (CSN) mobility support, Authentication, Authorization and Accounting (AAA) interworking with other technologies, and various services such as Location-Based Service (LBS), Multicast and Broadcast Service (MCBCS) etc. In this chapter, I will focus on the overview of WBBNS technology from the air interface perspective.

Figure 1 presents the aforementioned composition

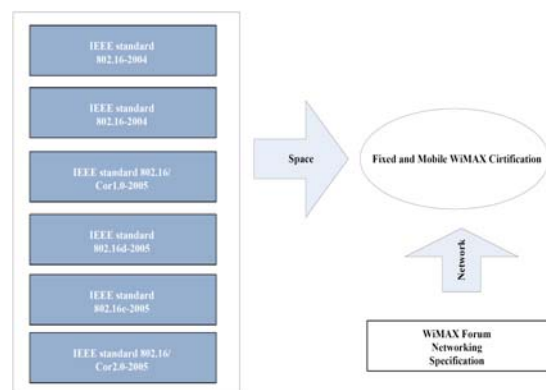

Fig.1:: Fixed and mobile WBBNS first release certification.

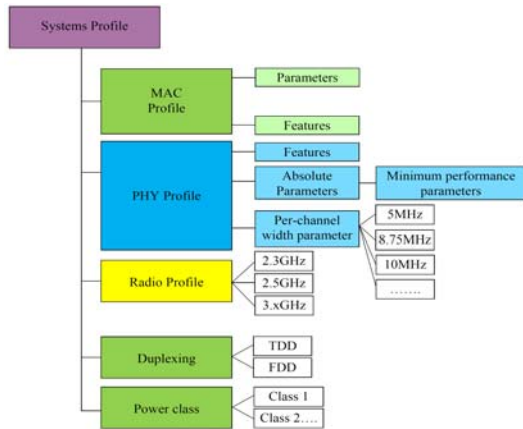

Fig.2:: Structure of fixed and mobile WBBNS system profile.

of the current WBBNS technology, commonly referred to as first release profile. Its air interface specifications consist of four related IEEE 802.16 Broadband Wireless Access Standards, that is, IEEE standard 802.16-2004, IEEE standard 802.16-2004/Cor.1-2005, IEEE standard 802.16e-2005 and the IEEE draft standard P802.16-2004/Cor.2. Not all of the optional features defined in these IEEE standards are implemented in WBBNS hardware and tested for certifications. Through extensive technical investigation analysis to build up the best competitive hardware, the WBBNS forum technical working in Thailand group published the first version of WBBNS system first profile in early 2007. The latest published version to date incorporated error fixes and minor corrections without touching the main features selected in the first revision. Figure 2 shown a more detailed view of the construction of the WBBNS system profile is presented from the space interface perspective. The system profile is composed of five sub-profiles, namely, PHY, MAC, radio, duplexing mode and power classes.

Even though there are many different combinations of center frequencies and channel bandwidths accommodating different regional spectrum regulations, all Release 1 mobile WBBNS products share the same PHY and MAC features (profiles) and the same duplex mode which is Time Division Duplex (TDD). In the following, some detailed descriptions of key PHY and MAC features in the mobile WBBNS system profile are offered.

2.2 Wireless Broadband Network System Description.

Our research within the framework of the joint (NTC) by the study and development of medical applications on the network, high-speed wireless broadband/how to implement research applications. Researchers from the biomedical engineering research activities at the proposal stage 1, and the Memo-

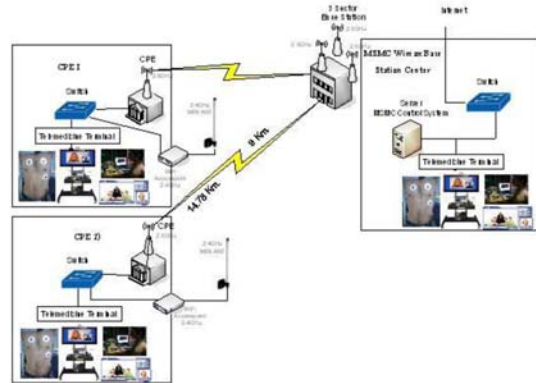

Fig.3:: Medical applications by connecting to the network to the second health district.

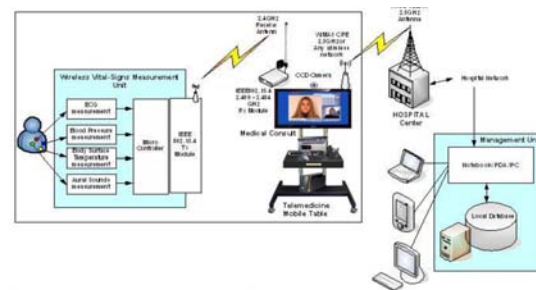

Fig.4:: Structure of telemedicine via WBBN.

randum of Agreement (MOU) between the NTC and the MSMC. The structure in Figure 3 and Figure 4, in various forms and with developments in other parts. Is planned within the framework of first and third sub-projects, working with researchers at the Research Society of Biomedical Engineering to the appropriateness and efficiency of research and development.

The operation of vital-signs in Figure 4 shows the following:-

- 1) How to measure the vital signs of patients. Patients must be attached to electrodes on the patient every time a measurement.
- 2) Signs are based on measurements obtained from the module receiver - radio frequency 2.4 MHz (standard IEEE 802.16.4), which has low power as possible. (Can be adjusted from 5-100 mW, which is to prevent harm to patients and medical equipment).
- 3) A patient's vital signs will be transmitted to the telemedicine table has been around less than 10 meters.
- 4) The CPE on the telemedicine table, it sends a signal to the WBBNS CPE to connect to the Medical Center, King of the Chakri Sirindhorn. HRH Princess Maha Chakri Sirindhorn. In this study, in a radius of 8-20 k.m.

This project has created a network of research and knowledge management, medical and public health



Fig.5:: Overview of medical application over High speed wireless broadband technology.

systems will be used to patient monitoring such as the heart sounds, lung sounds, electrocardiogram via WBBNS network.

Figure 5 is a model to measure vital signs, the medical doctor remotely via teleconference at the tele-consultation and treatment of a doctor, whether in the medical center's size or small health district. Physicians can provide patients via high-speed wireless broadband has the following functions: -

- 1) Measuring vital signs of patients. Patients must be attached to electrodes on the patient every time a measurement.
- 2) Vital signs were measured to the modules to transceiver frequency of 2.4 GHz with low power as possible. (Adjustable from 5-50 mW, which is to prevent harm to patients and medical equipment).
- 3) A patient's vital-signs will be sent to a nearby table during telemedicine in less than 10 meters.
- 4) The telemedicine equipment CPE on the table, it sends a signal to the WBBNS CPE to connect to a medical center in this study were within the radius of 80-20 km.
- 5) The research of this project has created a network of research and knowledge management, medical and public health will bring a variety of patient monitoring systems. Such as heart and lung sound monitoring, electrocardiogram monitoring or other vital-signs monitoring through WBBNS (Prototype shown in Figure 14 and how to measure the ECG over WBBNS).

2.3 Design of Implementation

ECG signal processing system design for long-distance wireless data transmission module for low power, this requires knowledge of many aspects. Namely, education, medical theory for the origin of the ECG using the basic design of electronic circuits, the development of micro-controllers, communication systems, and development of software in the computer to be able to perform. The research done in the design of the overall system will be structured as shown in Figure 6.

Figure 6 is shown the overall structure of the system consists of a portable device for the patient is

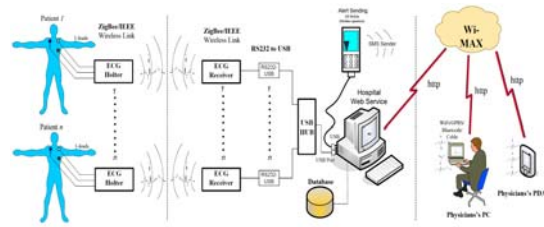

Fig.6:: The structure of the signal processing system in the ECG monitoring.

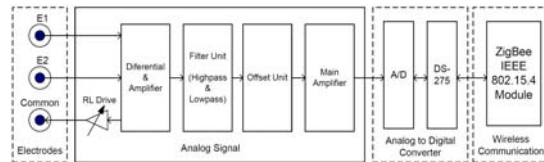

Fig.7:: The design of ECG monitoring via WBBN block diagram.

responsible for monitoring the ECG and transmit signals via a wireless network in the 100 meters to the computer display and storage. Under the analysis of signals for signs of unusual and could signal a warning to doctors who treat over the phone, this system is able to accommodate the connection of the patients were 8 people who use the system. They can be connected to a network computer with a user is an administrator, medical treatment and general personnel.

2.3.1 Design of ECG transmitter device over WBBN Backbone.

The design of the ECG of a channel and through a wireless network with a modular transceiver ZigBee is shown in Figure 7 contains the measured signal using the detection signals from the skin of patients with Electrodes, ECG. is represented by the voltage coming out with Differential Amplifier circuit and the voltage of electricity that can be used to study the function of the heart, the signal that it is bandwidth in the range between 1 - 100 Hz. for interference or radio frequency interference, etc. that may come from the patient himself, was then designed to amplify the signal and noise reduction by using the signal of Active device, such as the Operational Amplifier to reduce noise, the signal that it is. The analog signal will be sent to. Number PIC16F675 microcontroller, which is responsible for converting the signals into digital signals with a set of modules, ZigBee IEEE 802.15.4 transceiver to transmit a signal to the computer data center.

2.3.2 Computer programs for processing and notification of an emergency.

The hospital's computer server will act as a hub of information processing. Store and check for signs of the patient. It can sending a signal warning to

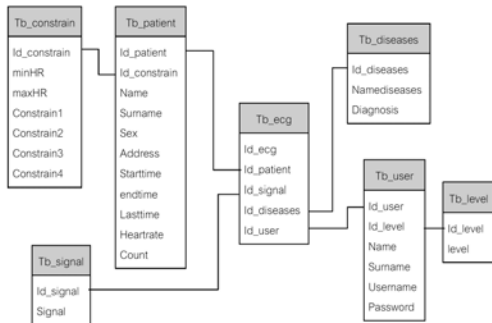

Fig.9:: Database of ECG signal processing through WBBNS.

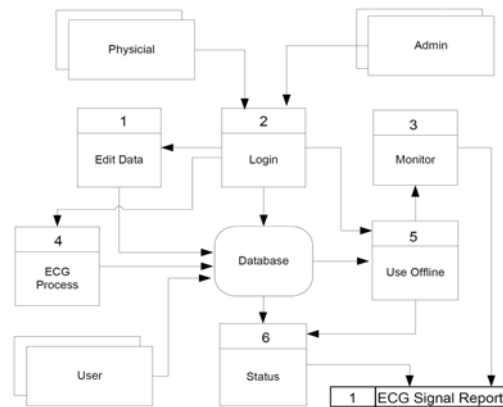

Fig.11:: Data Flow Diagram of web services over WBBNS and the internet.



Fig.10:: Measurement results are displayed in real time via WBBNS.

physicians and caregivers in an emergency. It consists of a set of program data for receive the software and data storage and processing of signals.

2.3.3 Receiving and storage of ECG data.

Hospital computer server will support the transmission of many patients at the same time. It is a server -based applications developed with Visual Basic working with multi-track processing at the same time in 2 parts. The acting in data management and signal processing in the receiving and storage of this data. It can be displayed in the connection status of each patient. And ECG signal graph of the many patients at the same time. In the other part is connected to an online database, which uses a MySQL database to support the user’s connection to the web service to the application data flow diagram is shown in Figure 8.

To work "Online" physician will be shows the vital-signs of the patient in real time before you have saved data in the database. And the "Offline" he can call the previous patient’s database. In the database design will be the structure shown in Figure 9.

Figure 10 is experimental device developed ECG monitoring via WBBN which the main program window will display a list of all patients in the database. And linker status in real time and display time data



Fig.12:: Shows the web of the ECG database via WBBN and the Internet.

from the received data. Time to end the transmission of data, number of connections that can detect heart rate. Users can select a patient’s ECG display in real time.

2.3.4 Web Services for connecting with users

PC as a hub or network switch of data, including Apache Web Server Version 2.2.3 PHP Script Language Version 5.1.6 and MySQL Database version 5.0.24a. Web services are web services connected with the development of the programming language PHP. Consists of showing the connection of the patient. The output signal E C G is a graph, most of the details of the patient And in parts of the graph to aid in the diagnosis, analysis, showing details of a data flow diagram in Figure 11.

On the part of the show via computer network, users will be able to show our patients with the same application on server and display real time status of the test results in Figure 12. It shows a web of the ECG signal via WBBN and internet.

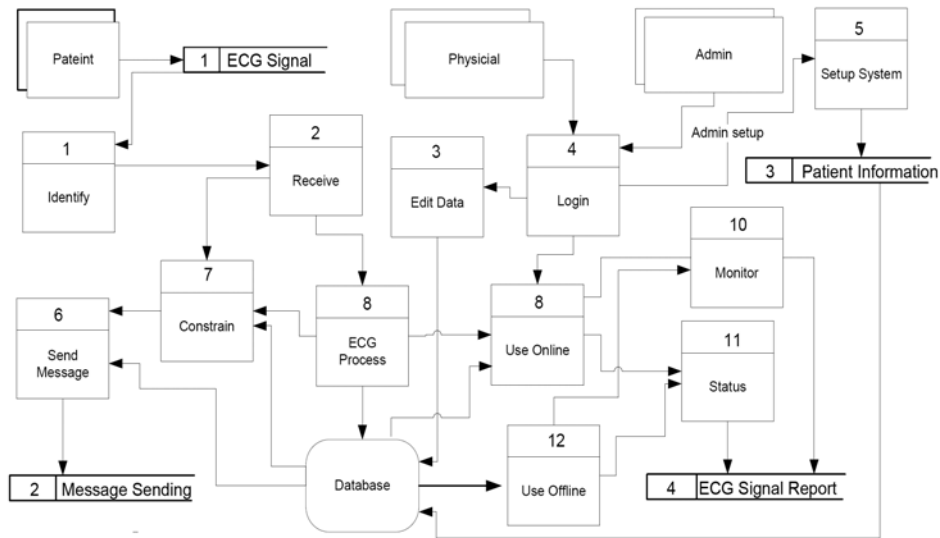

Fig.8:: The data flow diagram of ECG signal processing application.



Fig.13:: Shows the web of the ECG database via WBBN and the Internet.

2.3.5 WBNS Testing on-site at MSMC and Chiang Mai University

The application was developed by a medical team of researchers from Thailand Biomedical Engineering Research Association (ThaiBME), and Assoc.Prof.Dr. Suranan Noimanee Department of Computer Engineering faculty of Engineering Chiang Mai University, Thailand is shows in Figure 14.

Figure 16 is the shape of the spectrum range from 2.5 GHz antenna (Figure 18), which has studied the interference of the spectrum of the wireless broadband transmission and propagation from the antenna, then this is it. the frequency stability is equal to 2.36 p.p.m. at 27°C and is reduced to 0.003 p.p.m. when the GPS is already unlocked. Which is acceptable. (Default is 2.5 p.p.m. at 30°C and is reduced to 0.003 p.p.m. when the lock on the GPS). The system can



Fig.14:: ECG & HS equipment prototype with monitoring via WBBN network.

take on this project came from the Health and Medical Center. Medical doctor in the area surrounding the medical center, with the cover, it can retrieve data or vital signs of patients and can make a teleconsultation the telemedicine table or Notebook when he removed the patient according to smart phone of physician etc.

The MSMC has been supplying, installing, and testing of network devices and connections to Buangsarn and Chumphon health district, where the system has the following main components:-

- 1) Base Transceiver Station (BTS) devices.
- 2) Provisioning server devices.
- 3) EMS server device, such as VoIP server, Video server etc.
- 4) CPE (Customer Premise Equipment) devices.

The main function of each device can be explained as follow:-

- 1) BTS device serves as a wireless bridge can be send data to the CPE device across the state of the LOS (Line-of-Sight) and NLOS (None-Line-of-Sight) with radius to be covered as far as 8 k.m., or may be



Fig.15:: Tele-Consultation and physician see patients from around the home.

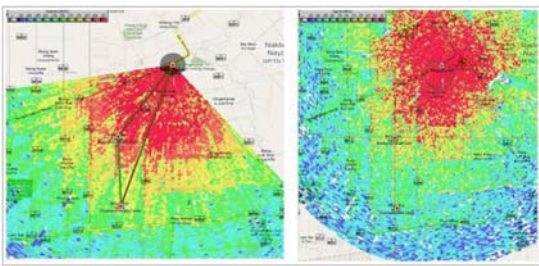

Fig.16:: Radiation pattern of 3-sectors antenna system, the distance between the MSMC to two health sub-district.



Fig.17:: The 3-sectors WBBNs antenna at Health center and MSMC building.



Fig.18:: The 3-sectors BTS antenna installation.

increased up to 32 k.m. if you change the distance of the device to get BTS.

2) Provisioning Server device acts as a device to monitor the implementation of the CPE device to get access to the network. The CPE devices to get access to detailed information of its own Packet to/from the device, so the BTS device will be forwarded to the Provisioning Server make sure that access to work or not. This test can pick up - delivery needs.

3) EMS Server device will check the status of each device is not functioning normally or not. Using the SNMP protocol and status message when the device is working deviated from the norm. This will make management easier.

4) CPE device is a terminal device for use at the local health district, both by combining the functionality of the Transceiver, Modem, and the antenna together (Figure 18) by activating the device CPE is trying to connect BTS equipment for use on networks.

They are many type of CPE devices, such as indoor a desktop application (RSU: Residential Subscriber Unit), are active outdoors (OSU: Outdoor Subscriber unit), are installed on the vehicle. (If installed at an ambulance. The physician's can visit patients at home) for use in mobile (MSU: Mobile Subscriber Unit) and the type installed on a portable computer (PC Card). Thus, in analyzing the radio signals (Terrain Analysis) of the BTS (Base Transceiver Station) devices in Figure 16 is derived from the design of the research team, which can be described as follows:-

From the simulation on the Terrain database using Google Earths software by providing equipment, BTS stuck at a height of about 60 meters (deck floor 16th of the MSMC building) and use the 90 degrees antenna sector and OSU. CPE is the receiver altitude of 2 meters from that which we can detect the signal from each point as shown in Figure 11. The results of the test antenna gain is equal to 13dBd give Rx Level = 61.1 dBm at a distance of 8.67 km is the Path Loss = 120.67 dB Interference by the location of the radio was BuengSan health center and other high

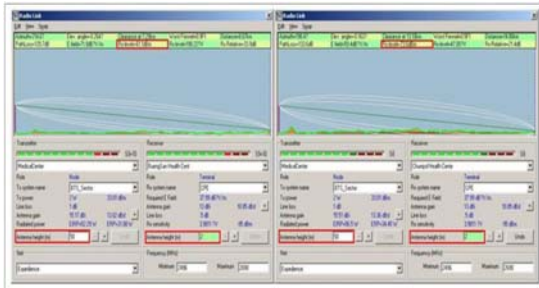

Fig.19:: WBBNS radiation pattern testing at Chumpon health center.

voltage equipment. Similarly, the Chumpon health center will be a different test at the 14.80 km distance as shown in Figure 19.

2.3.6 Primary Health Care Mobile Doctor Around MSMC

This project is medical services, and it will enhance medical services and quality systems. Primary Care and Public Health Network's Princess Sirindhorn Medical Center. According to the main goal of primary care: namely Accessibility, Continuity, Comprehensiveness, Coordination, and Community participation. To study and develop a system based on people-centered primary care, and the participation of citizens in the community. To study and design consultancy, while visiting patients home by application of information and communications technology used to visit them. And to develop a system of instruction courses in family medicine. Group of chronically ill, disabled and disadvantaged people in the area of responsibility of the network's primary care medical centers. Around MSMC in Ongkharak Nakhon Nayok the people of the district radius propagation by high-speed wireless broadband technology to the district assembly for the eight villages in Figure 19-23. For various reasons these to solve problems. And thus a source of primary care, community health centers nearest public mind. And provides the goals and concepts of 1A4C. So we have a concept of Primary Health Care Mobile Doctor over high speed wireless broadband system.



Fig.20:: Health service doctor to visit patients at home.



Fig.21:: The village headman photographed Together.



Fig.22:: Experimental Tele-Home Health Care Clinic and the patient's home.



Fig.23:: MD. Krit and his patient Tele-Home Health Care Clinic and the patient’s home.



Fig.24:: Patient Tele-Home Health Care project.

3. RESULTS AND CONCLUSION

This research has been developed which medical data from MSMC to date ECG and other medical application over wireless broadband network have been implemented. Such as the ECG signal is estimated to chart a more accurate time series analysis, which we will use the example of the value that occurs over time with equally spaced. The movement of the time series is likely a variation of time series. The trend line is used in the study estimates. Also known as regression analysis. There are different ways such as, logarithmic, polynomial, including the Financial Component, R-squared, the moving average. This research is intended to predict a smooth techniques of ECG signal display. In the first period which will the number of four-wave, such as P-wave, QRS-wave, T-wave and U-wave, so they are to smooth the signal if the value is adjusted to a value that is wrong as shown in Figure 25.

Figure 25. A comparison of the signal from the flat with a special exponential moving average and loga-

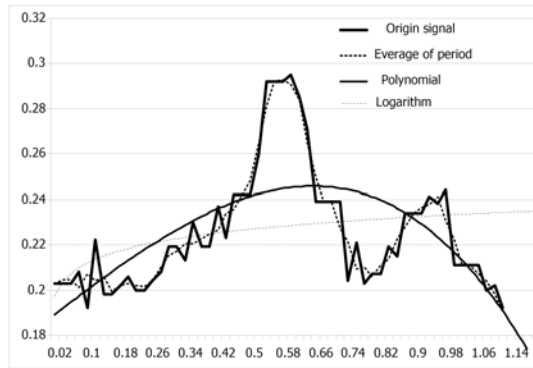

Fig.25:: Regression graphs with recession by various means.

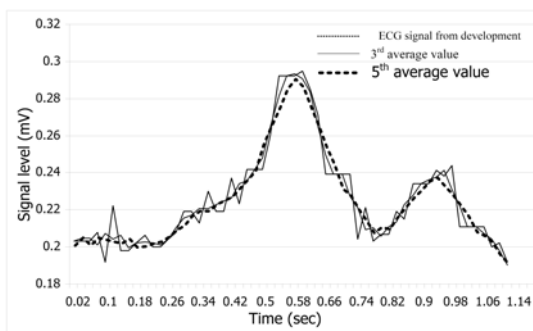

Fig.26:: Shows a comparison of the equation moving average signals in different time periods.

rithmic functions. In this paper, we use a moving average function to do not put all the data correlation. , but It will be compared at a series of n (n is the number of periods to compare data sets). The method to calculate the moving average the following.

$$S_t = \frac{X_t + X_{t-1} + \dots + X_{t-n+1}}{n} \quad (1)$$

Where is

S_t = forecast at time t.

X_t = the observation time t.

n = number of data used averages (period).

Figure 26 can be seen that when increasing the n value of the experimental period by a moving average to smooth the edges even more. But the time period will result in too small waves disappear. In this study, we chose a time period equal to 3 (n = 3). They picked up too much time to make the signal level lower than normal. The signal does not match the actual measurement signal. And when less than 3 periods of time will make the adjustment on uneven. The experimental values obtained from the ECG signal measurement device developed to measure and collect data as a numeric value in every 10 mS by using an application developed.

4. CONCLUSION

With the first year of research funding is still difficult to design systems which have a WBBNS base station delays the import of radio communications, coordination between the organizations, etc. However, researchers have tried to find a solution. But trying to find a solution to the project to continue research. The researcher have tried to research the budget process to ensure maximum benefits. As the first recipient of research grants from the NTC to operate such a project would have difficulty understanding the structure of the high-speed wireless broadband network documenting the progress report in accordance with MOU, etc. This project benefits widely.

5. ACKNOWLEDGMENT

The authors also would like to Professor Dr.Prasit Prapinmongkolkarn chairman of Office of National Telecommunications Broadcasting and Telecommunication Commission (NBTC) for his invaluable assistance in funding research. This work was supported by Department of Biomedical Engineering, Faculty of Engineering, and Faculty of Medicine, Srinakharinwirot University, Thailand.

References

- [1] Office of National Telecommunications Broadcasting and Telecommunication Commission (NBTC)s Medical Application report 2010.
- [2] Planet Communications Asia Co., Ltd. "WiMAX Network Design 2010," *Planet communication Confidential Proprietary*. Pp. 46-104.
- [3] K.Noimaneer and S.Noimaneer, "Medical Consult-Based System for Diagnosis on WiMAX Technology," *International Journal of Applied Biomedical Engineering*, vol.3 No.1 2010. Pp.51-55
- [4] K.Noimaneer, S.Noimaneer, La-Oopugsin, S.Wattanasirigoonchai. "Development of e-Health Application for Medical Center in National Broadband Project," BMEiCon 4th Biomedical International Conference 2011.



Suranan Noimaneer received B.Eng.(Electrical Engineering), M.Eng. (Electrical Engineering), and Ph.D. (Material Science) degree from Institute of Technology and Vocational Education Bangkok, Chiang Mai University in 1984, 1995 and 2008. He joined the Thai BME Association, Thailand in 2002. He has been engaged in research and development efforts devoted to computer application systems for biomedical engineering. He is current a lecturer in department of Forensic Science, K.University.



Wongwit Senawongse received B.Eng. (BME), M.Sc., and Ph.D. degree from University of Kent Imperial Collage, London, England in 1994, 1996 and 2002. He joined the Thai BME Association, Thailand in 2007. He has been engaged in research and development efforts devoted to computer application systems for biomedical engineering. He is current a lecturer in the Department of Biomedical Engineering, Srinakharinwirot University, Thailand.



Suchada Tantisatirapong received B.Eng. (Computer Engineering), MEngSc. (BME) and Ph.D. (BME) degree from National University of Singapore, Singapore, University of New South Wales, Australia and University of Birmingham, United Kingdom in 2006, 2007 and 2015. Since 2015, she has joined the Thai BME Association, Thailand and currently is a lecturer staff of Biomedical Engineering Department, Srinakharinwirot University, Thailand.



Kittinan Noimaneer received B.Eng. (Computer Engineering) and M.Eng. (BME), degree from Chiang Mai University and King Mongkuts Institute of Technology Ladkrabang (KMUTL) in 2008 and 2011. He is current a lecturer in the Department of Computer Engineering, Rajamangala University of Technology Lanna (RMUTL), Chiang Mai, Thailand.